

# Computer Graphics

---

Bing-Yu Chen  
National Taiwan University

# Viewing in 3D

---

- ❑ 3D Viewing Process
  - ❑ Classical Viewing and Projections
  - ❑ 3D Synthetic Camera Model
  - ❑ Specification of an Arbitrary 3D View
  - ❑ Parallel Projection
  - ❑ Perspective Projection
  - ❑ 3D Clipping for Canonical View Volume
-

# 3D Viewing Process

---

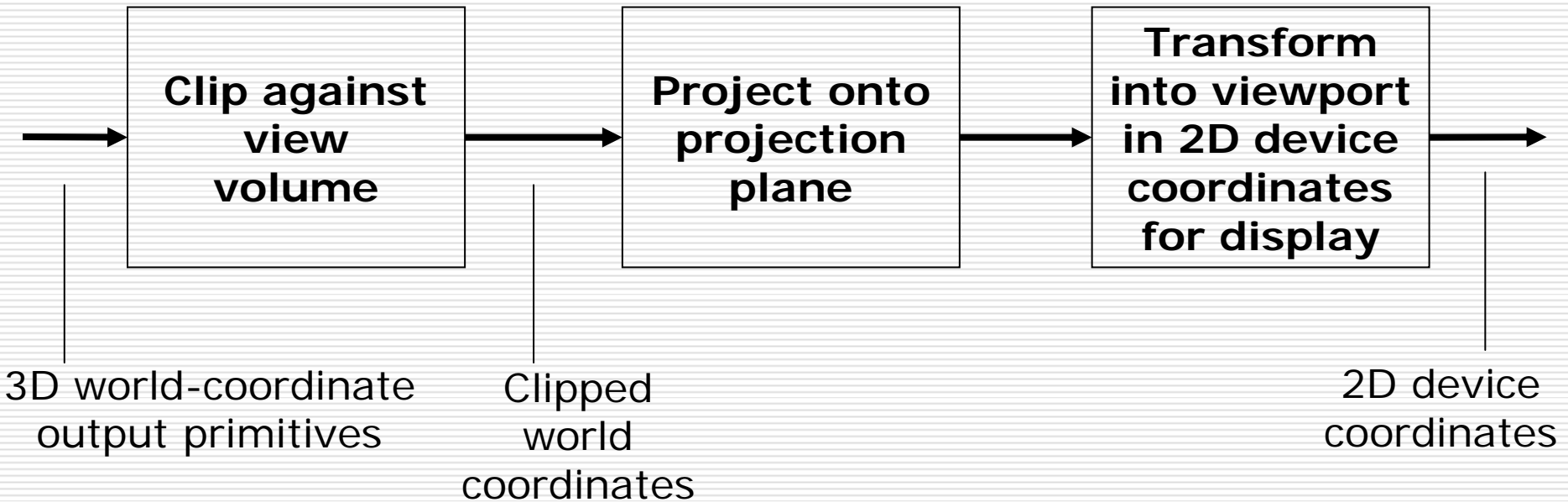

# Classical Viewing

---

- Viewing requires three basic elements
    - One or more objects
    - A viewer with a projection surface
    - Projectors that go from the object(s) to the projection surface
  - Classical views are based on the relationship among these elements
    - The viewer picks up the object and orients it how she would like to see it
  - Each object is assumed to be constructed from flat *principal faces*
    - Buildings, polyhedra, manufactured objects
-

# Classical Projections

---



Front elevation

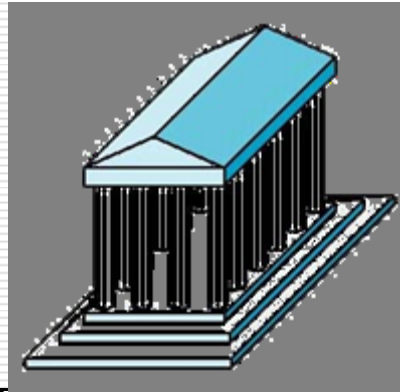

Elevation oblique

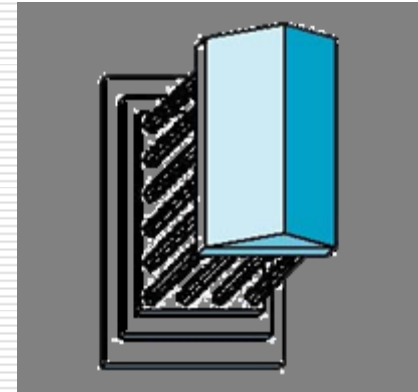

Plan oblique

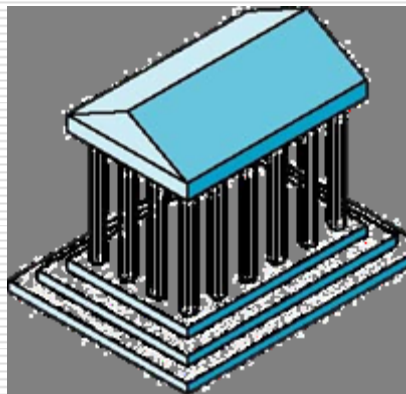

Isometric



One-point perspective

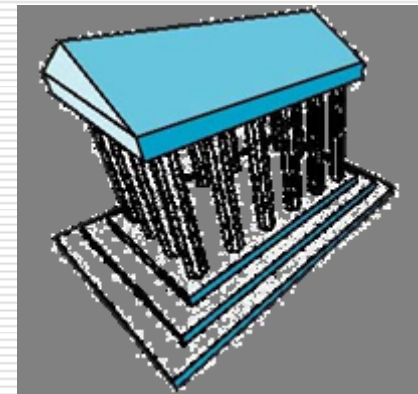

Three-point perspective

---

# 3D Synthetic Camera Model

---

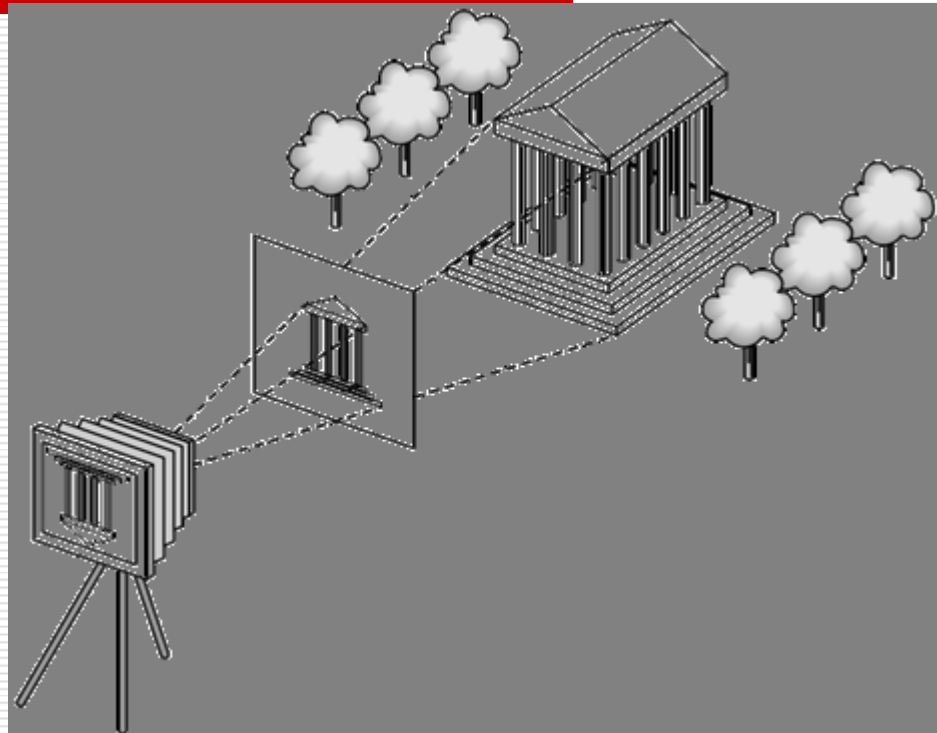

- The **synthetic camera model** involves two components, specified *independently*:
    - objects (a.k.a **geometry**)
    - viewer (a.k.a **camera**)
-

# Imaging with the Synthetic Camera

---

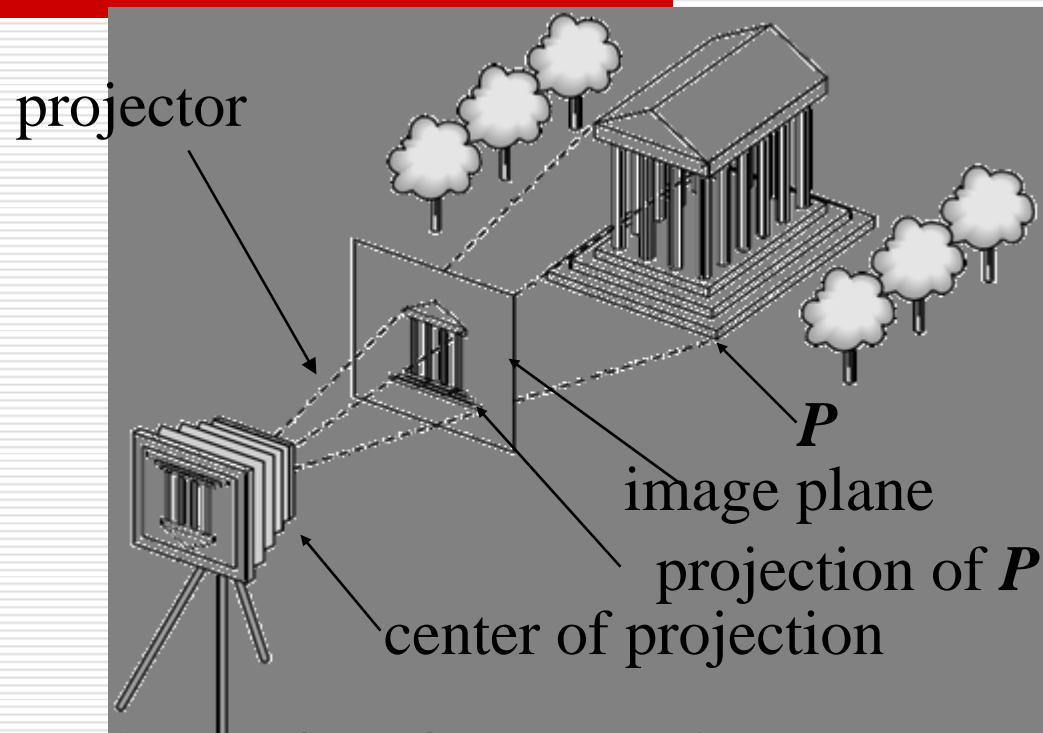

- ❑ The image is rendered onto an **image plane** or **project plane** (usually in front of the camera).
- ❑ **Projectors** emanate from the **center of projection** (COP) at the center of the lens (or pinhole).
- ❑ The image of an object point  $P$  is at the intersection of the projector through  $P$  and the image plane.

# Specifying a Viewer

---

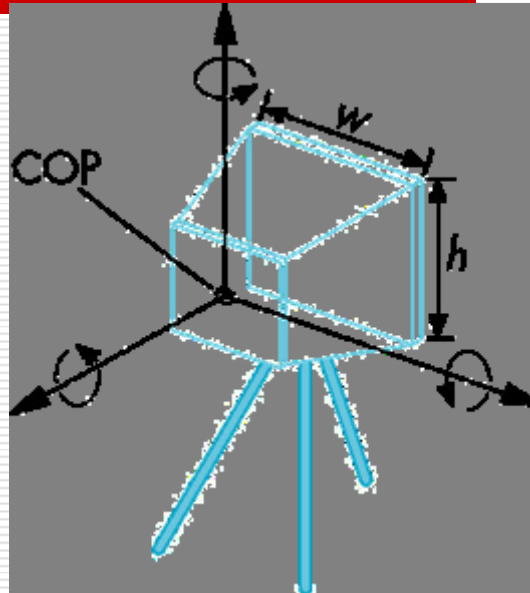

- Camera specification requires four kinds of parameters:
    - *Position*: the COP.
    - *Orientation*: rotations about axes with origin at the COP.
    - *Focal length*: determines the size of the image on the film plane, or the **field of view**.
    - *Film plane*: its width and height, and possibly orientation.
-



# Projections

---

- **Projections** transform points in  $n$ -space to  $m$ -space, where  $m < n$ .
- In 3D, we map points from 3-space to the **projection plane (PP)** along projectors emanating from the **center of projection (COP)**.

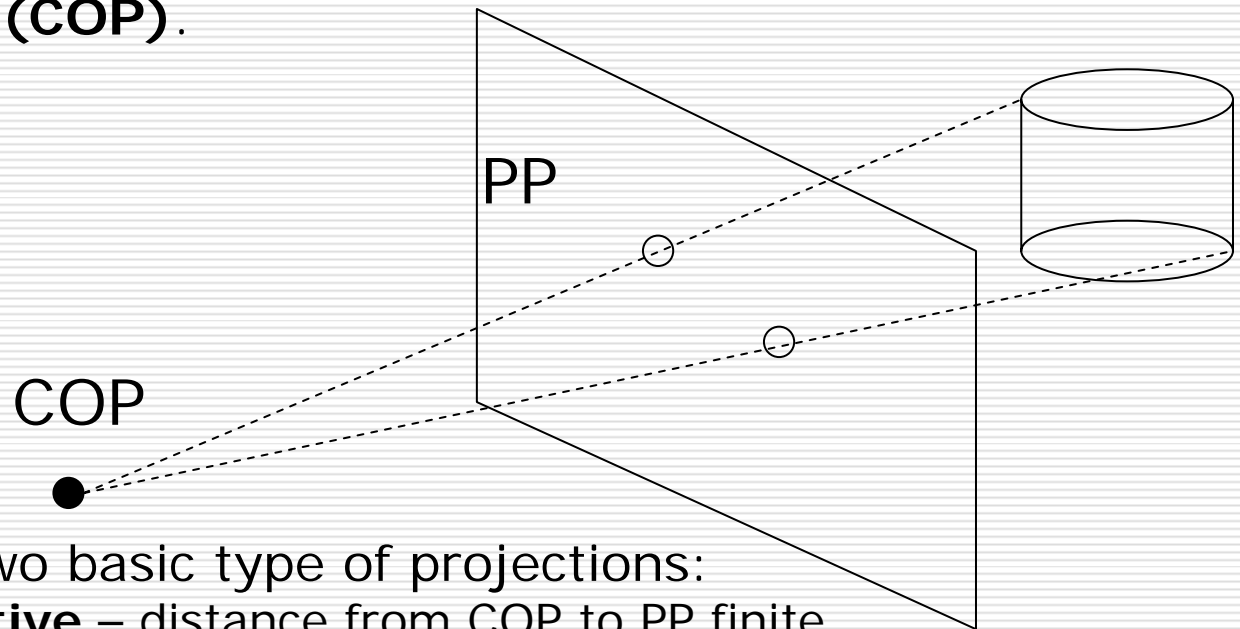

- There are two basic type of projections:
    - **Perspective** – distance from COP to PP finite
    - **Parallel** – distance from COP to PP infinite
-

# Perspective vs. Parallel Projections

---

- ❑ Computer graphics treats all projections the same and implements them with a single pipeline
  - ❑ Classical viewing developed different techniques for drawing each type of projection
  - ❑ Fundamental distinction is between parallel and perspective viewing even though mathematically parallel viewing is the limit of perspective viewing
-

# Perspective vs. Parallel Projections

---

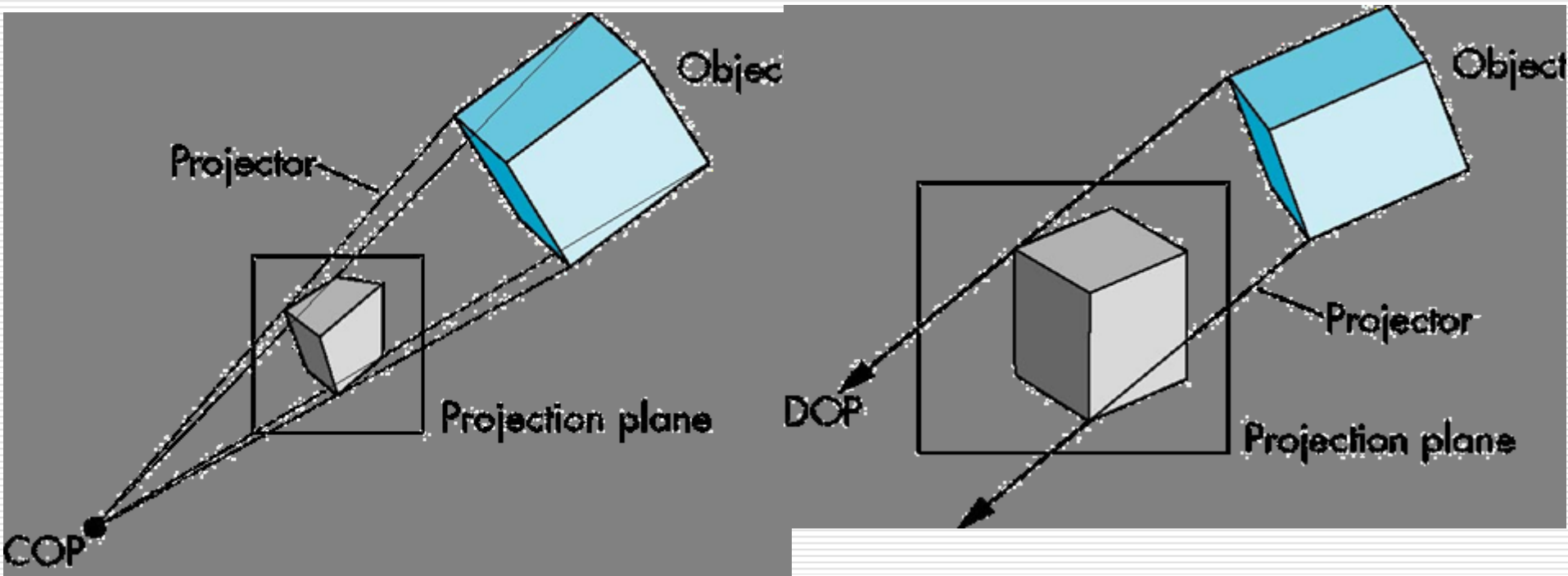

# Taxonomy of Planar Geometric Projections

---

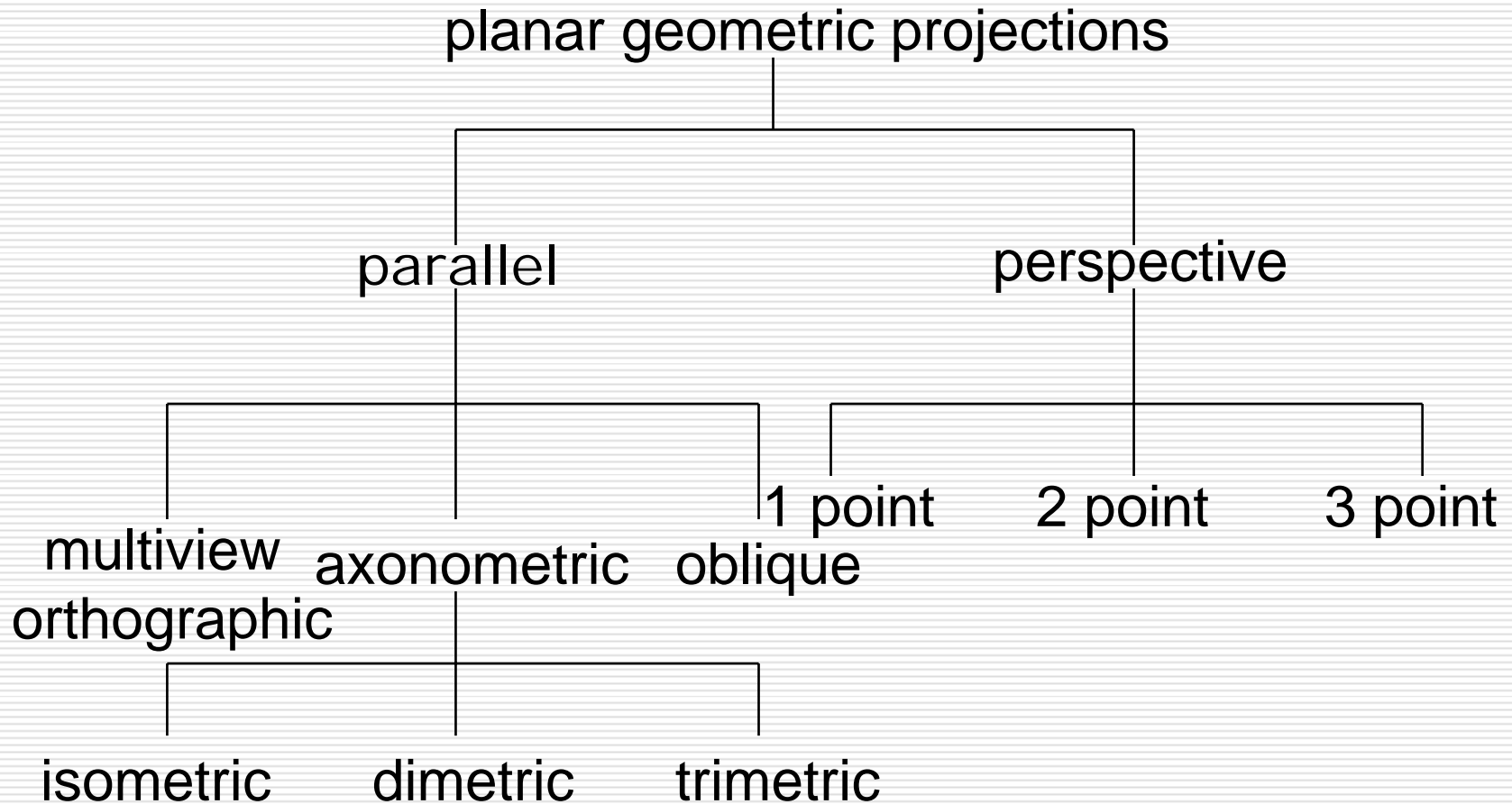

# Orthographic Projection

---

Projectors are orthogonal to projection surface

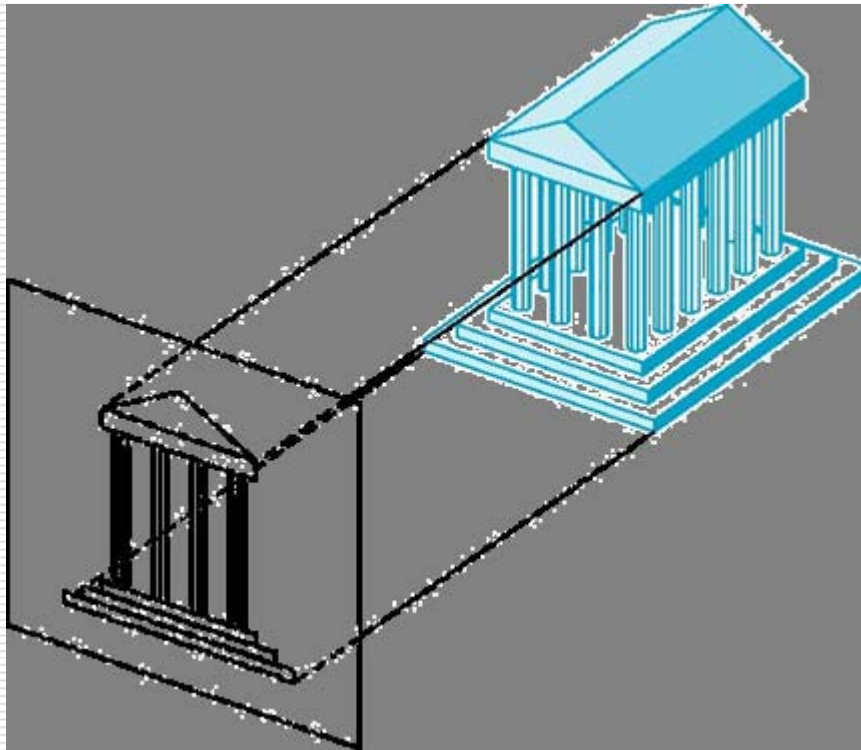

# Multiview Orthographic Projection

---

- ❑ Projection plane parallel to principal face
- ❑ Usually form front, top, side views

isometric (not multiview orthographic view)

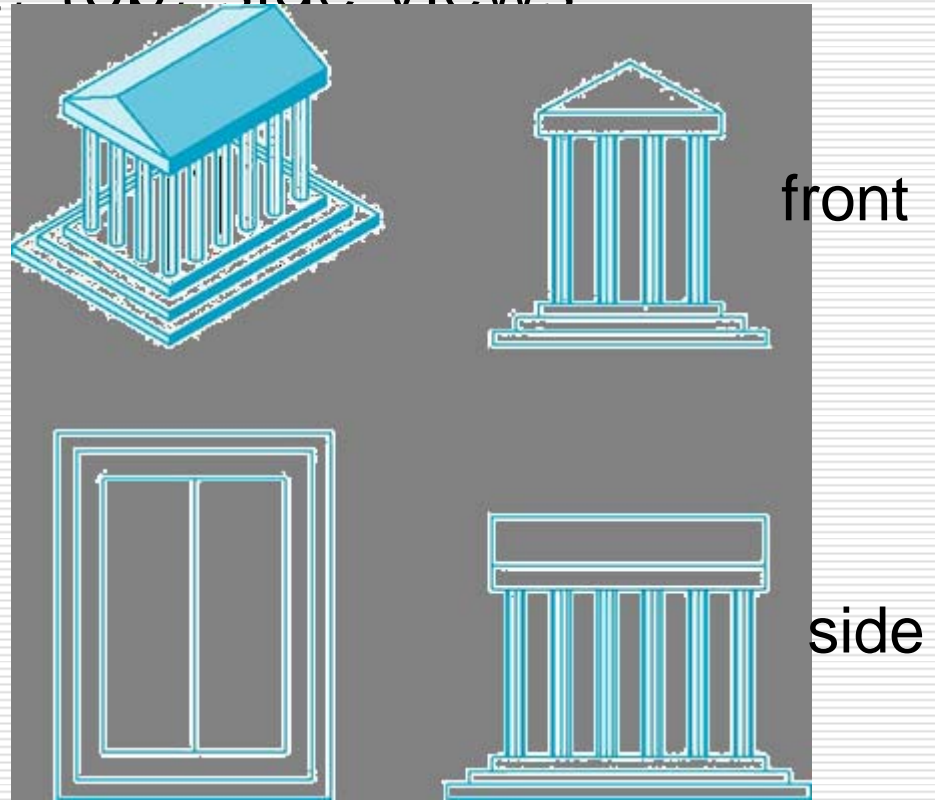

in CAD and architecture,  
we often display three  
multiviews plus isometric

# Advantages and Disadvantages

---

- Preserves both distances and angles
    - Shapes preserved
    - Can be used for measurements
      - Building plans
      - Manuals
  - Cannot see what object really looks like because many surfaces hidden from view
    - Often we add the isometric
-

# Axonometric Projections

---

Allow projection plane to move relative to object

classify by how many angles of a corner of a projected cube are the same

none: trimetric  
two: dimetric  
three: isometric

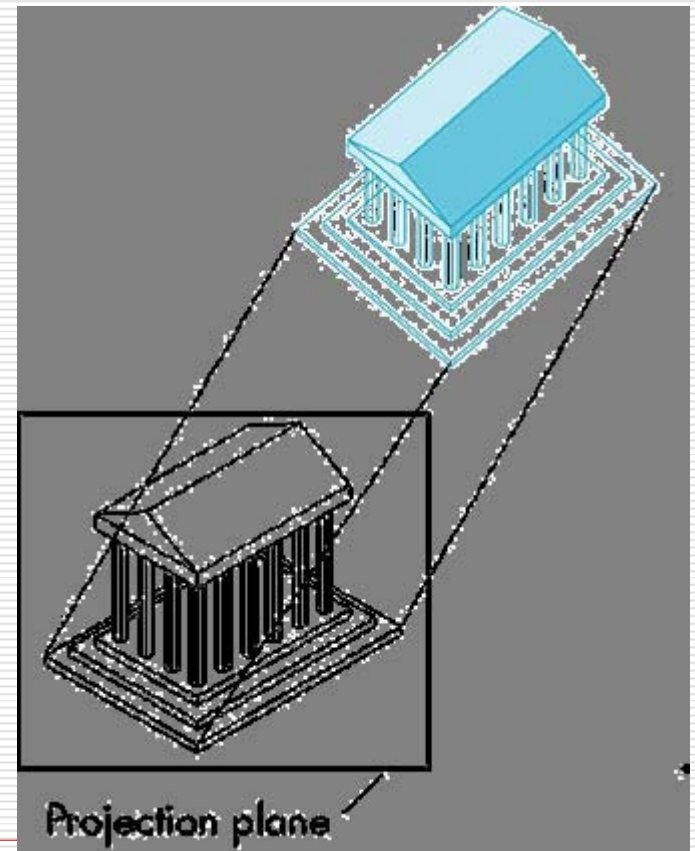
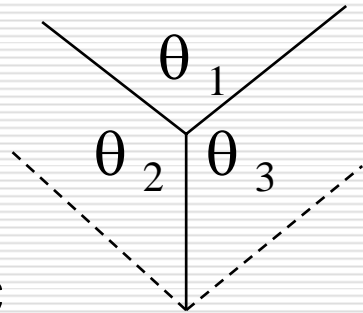



# Types of Axonometric Projections

---

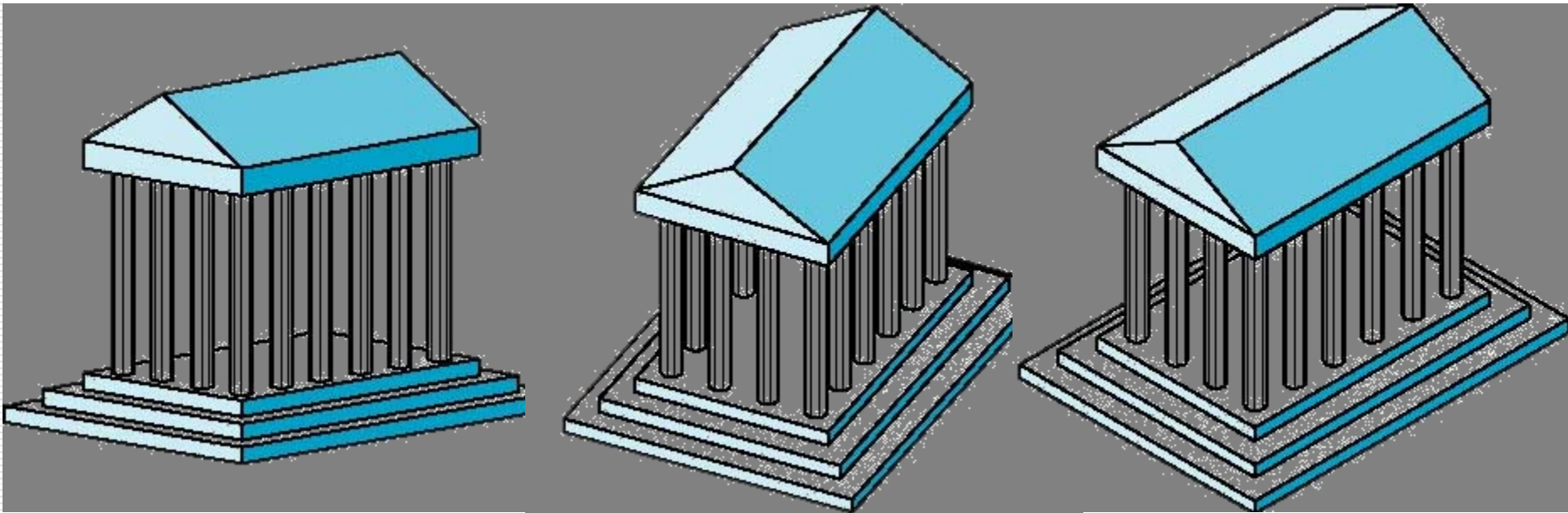

Dimetric

Trimetric

Isometric

---

# Advantages and Disadvantages

---

- Lines are scaled (*foreshortened*) but can find scaling factors
  - Lines preserved but angles are not
    - Projection of a circle in a plane not parallel to the projection plane is an ellipse
  - Can see three principal faces of a box-like object
  - Some optical illusions possible
    - Parallel lines appear to diverge
  - Does not look real because far objects are scaled the same as near objects
  - Used in CAD applications
-

# Oblique Projection

Arbitrary relationship between projectors and projection plane

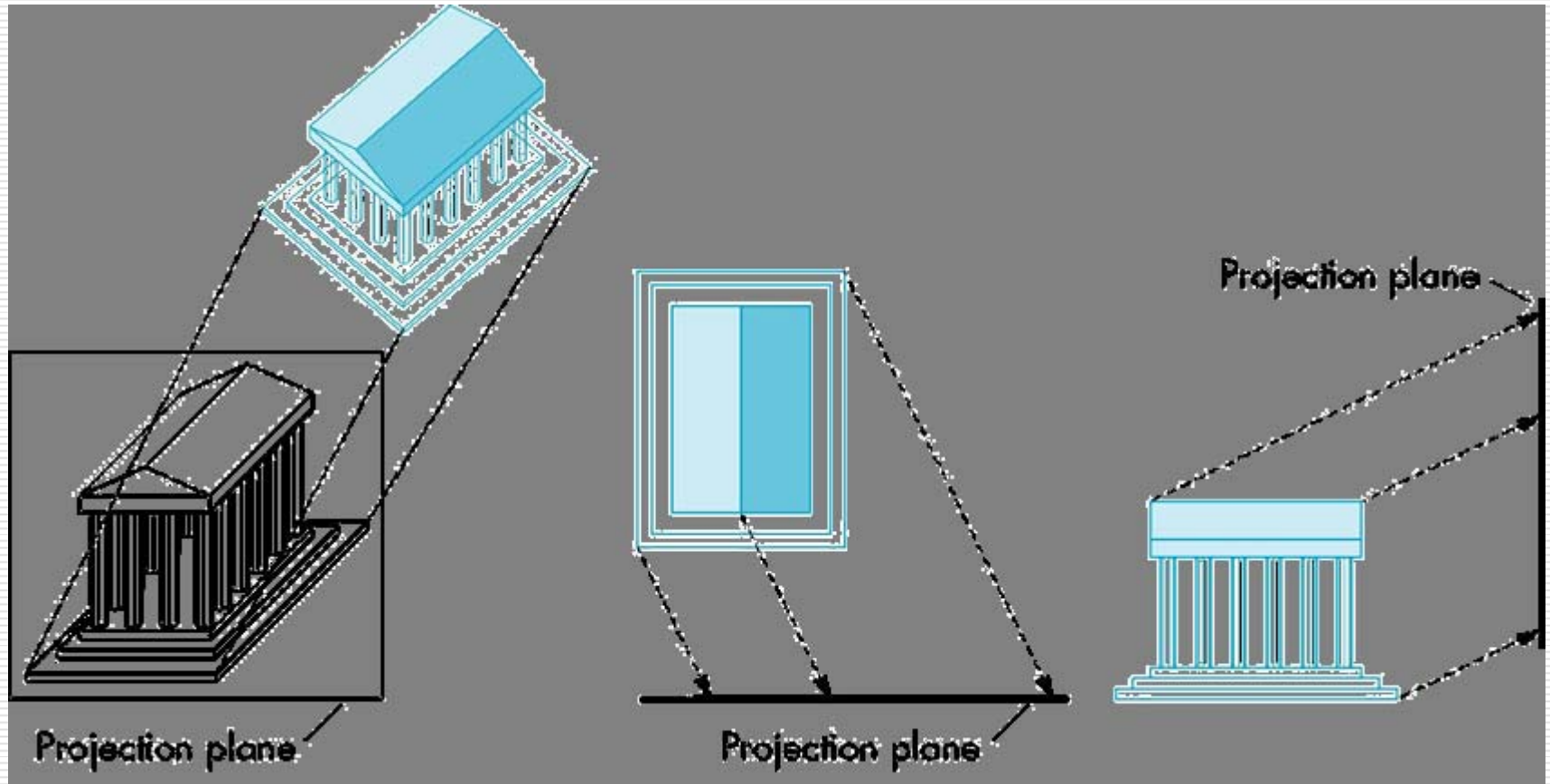

# Advantages and Disadvantages

---

- Can pick the angles to emphasize a particular face
  - Architecture: plan oblique, elevation oblique
- Angles in faces parallel to projection plane are preserved while we can still see “around” side

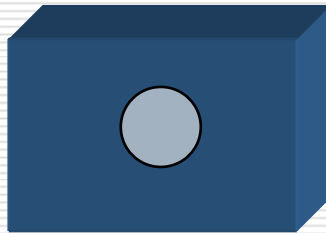

- In physical world, cannot create with simple camera; possible with bellows camera or special lens (architectural)
-

# Specification of an Arbitrary 3D View

---

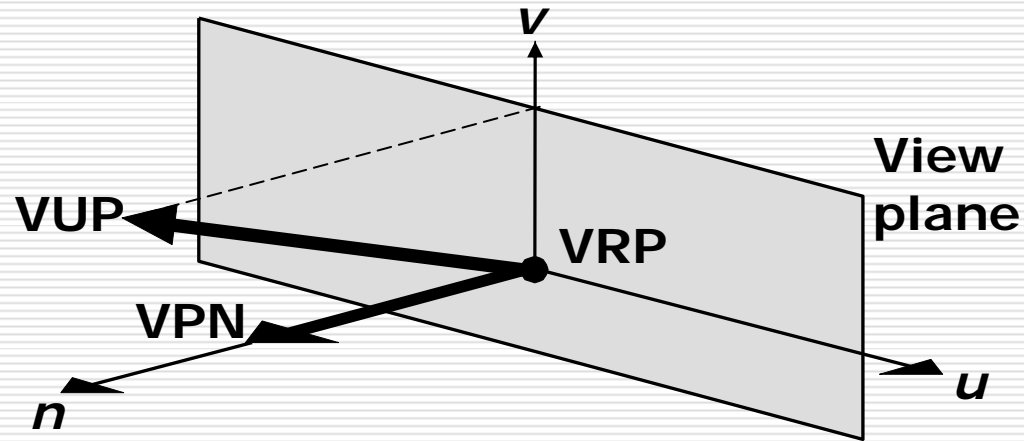

- VRP: view reference point
  - VPN: view-plane normal
  - VUP: view-up vector
-



# Infinite Parallelepiped View Volume

---

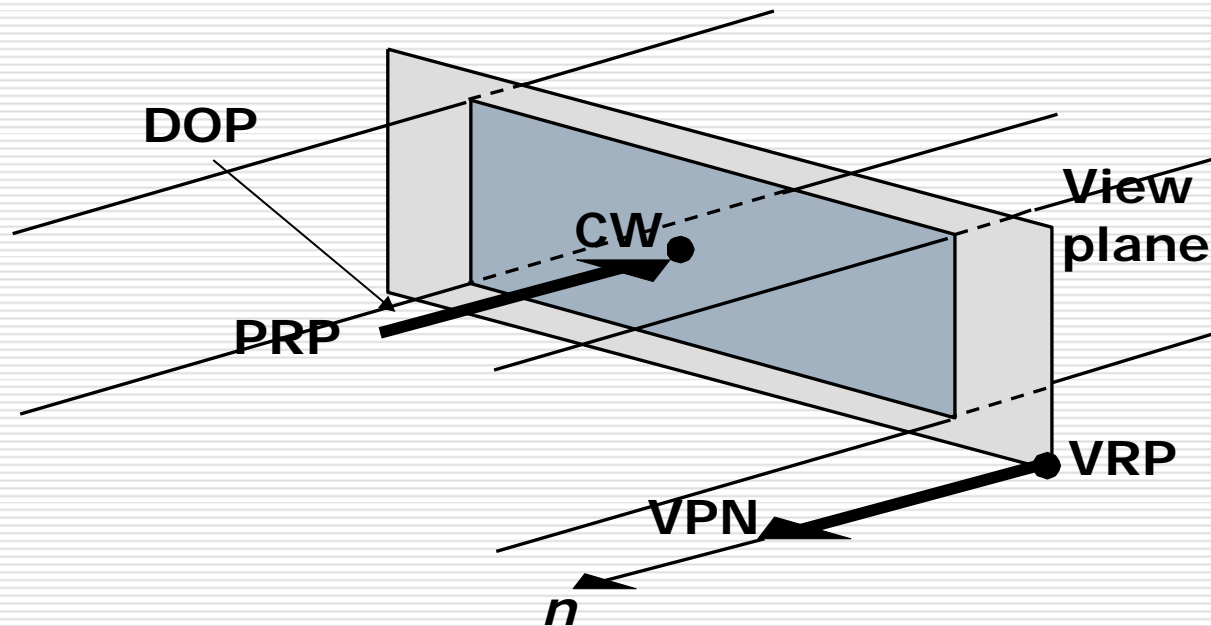

- **DOP**: direction of projection
  - **PRP**: projection reference point
-

# Truncated View Volume for an Orthographic Parallel Projection

---

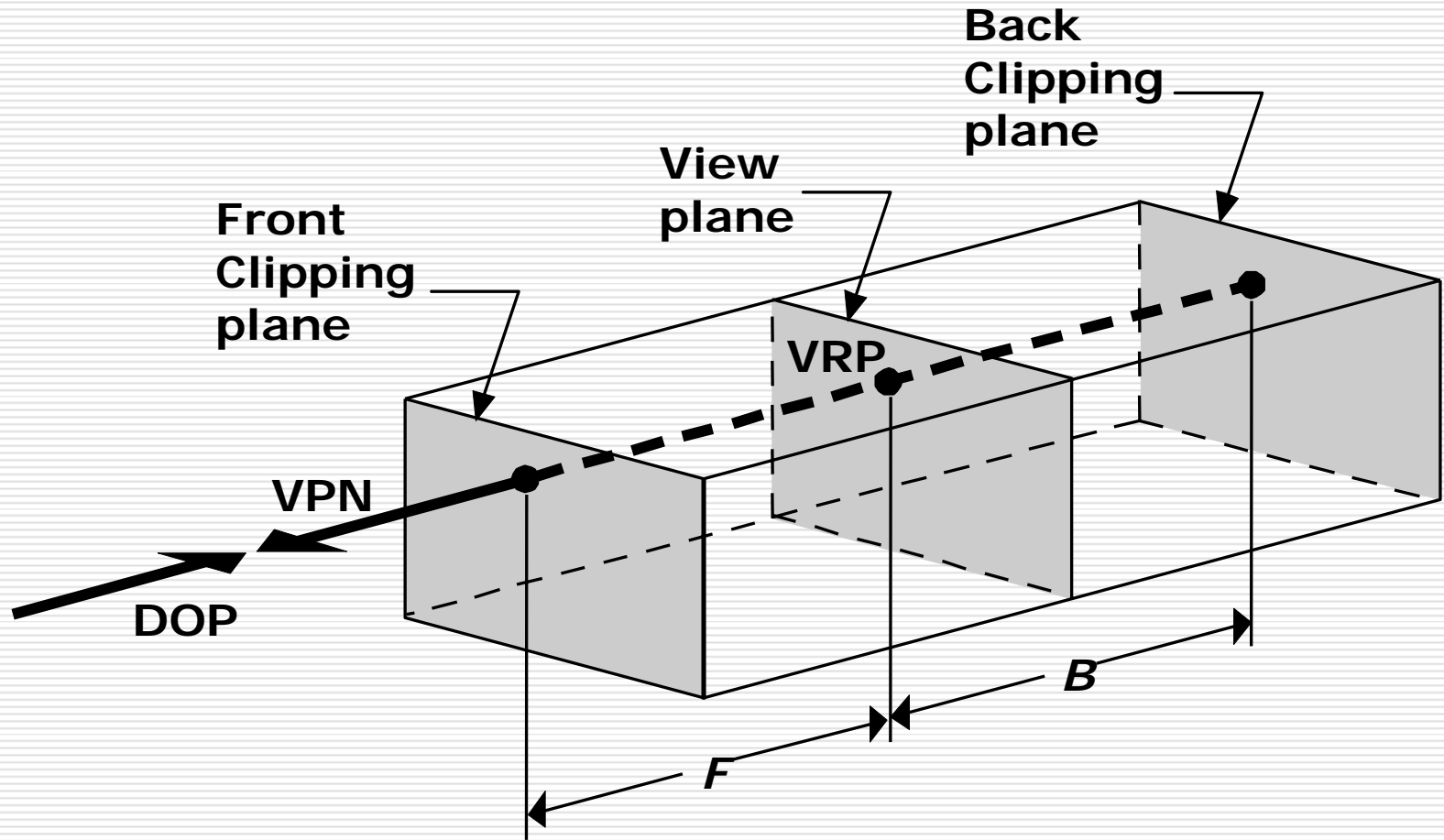



# The Mathematics of Orthographic Parallel Projection

---

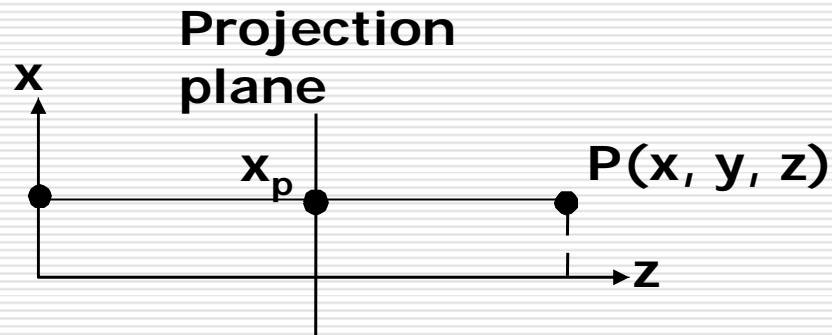

View along  $y$  axis

View along  $x$  axis

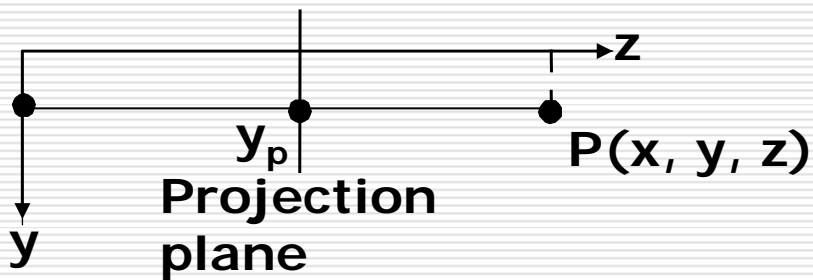

$$x_p = x; y_p = y; z_p = 0$$

$$M_{ort} = \begin{bmatrix} 1 & 0 & 0 & 0 \\ 0 & 1 & 0 & 0 \\ 0 & 0 & 0 & 0 \\ 0 & 0 & 0 & 1 \end{bmatrix}$$

# The Steps of Implementation of Orthographic Parallel Projection

---

- ❑ Translate the VRP to the origin
- ❑ Rotate VRC such that the VPN becomes the z axis
- ❑ Shear such that the DOP becomes parallel to the z axis
- ❑ Translate and scale into the parallel-projection canonical view volume

$$N_{par} = S_{par} \bullet T_{par} \bullet SH_{par} \bullet R \bullet T(-VRP)$$

---

# Perspective Projection

---

Projectors converge at center of projection

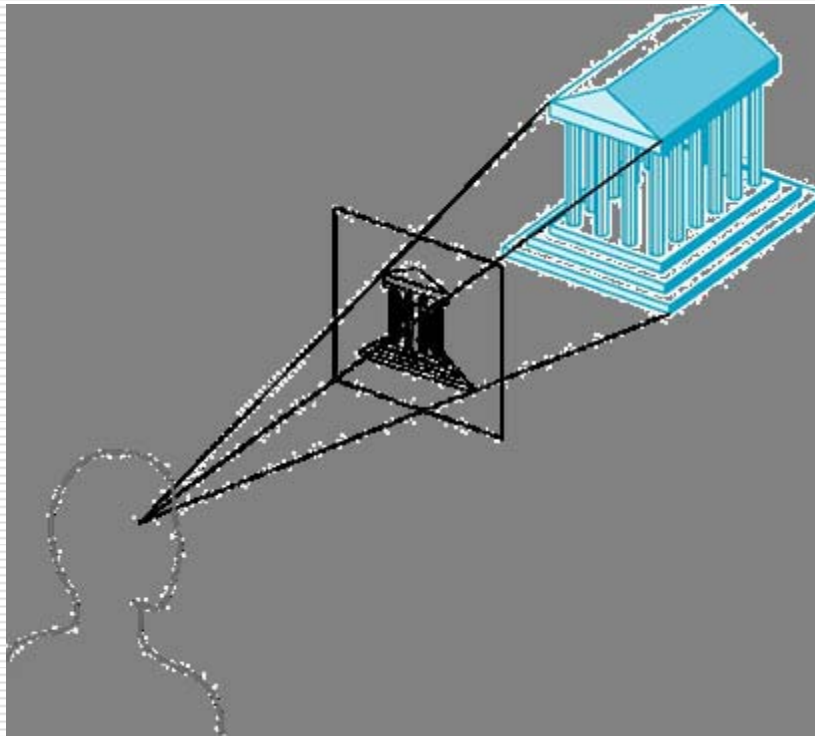



# Perspective Projection (Pinhole Camera)

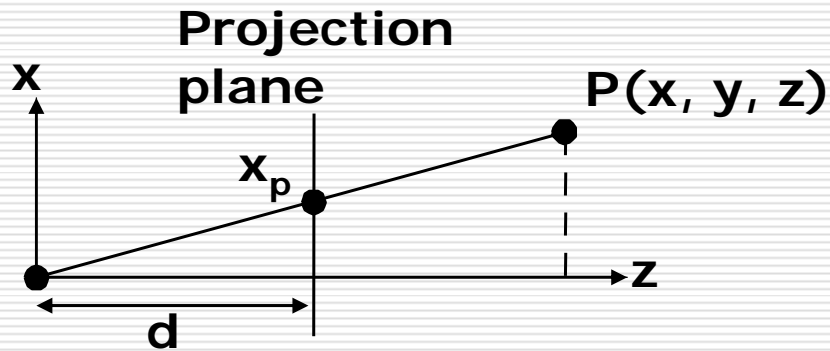

View along  $y$  axis

View along  $x$  axis

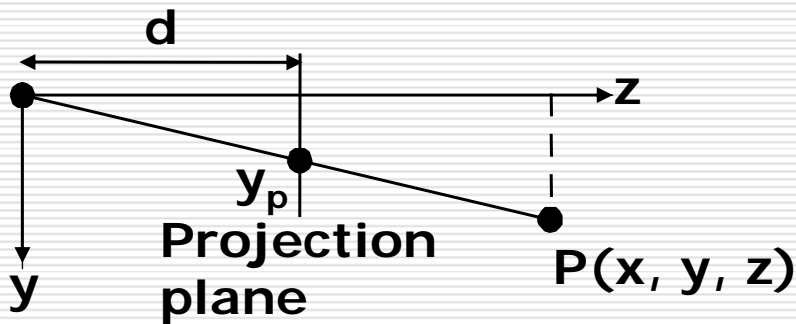

$$\frac{x_p}{d} = \frac{x}{z}; \frac{y_p}{d} = \frac{y}{z}$$

$$x_p = \frac{x}{z/d}; y_p = \frac{y}{z/d}$$

$$M_{per} = \begin{bmatrix} 1 & 0 & 0 & 0 \\ 0 & 1 & 0 & 0 \\ 0 & 0 & 1 & 0 \\ 0 & 0 & 1/d & 0 \end{bmatrix}$$

# Perspective Division

---

$$\begin{bmatrix} x_p \\ y_p \\ z_p \\ 1 \end{bmatrix} = \begin{bmatrix} X \\ Y \\ Z \\ W \end{bmatrix} = M_{per} \bullet P = \begin{bmatrix} 1 & 0 & 0 & 0 \\ 0 & 1 & 0 & 0 \\ 0 & 0 & 1 & 0 \\ 0 & 0 & 1/d & 0 \end{bmatrix} \bullet \begin{bmatrix} x \\ y \\ z \\ 1 \end{bmatrix} = \begin{bmatrix} x \\ y \\ z \\ \frac{z}{d} \end{bmatrix}$$

However  $W \neq 1$ , so we must divide by  $W$  to return from homogeneous coordinates

$$(x_p, y_p, z_p) = \left( \frac{X}{W}, \frac{Y}{W}, \frac{Z}{W} \right) = \left( \frac{x}{z/d}, \frac{y}{z/d}, d \right)$$

---

# The Steps of Implementation of Perspective Projection

---

- ❑ Translate the VRP to the origin
- ❑ Rotate VRC such that the VPN becomes the z axis
- ❑ Translate such that the PRP is at the origin
- ❑ Shear such that the DOP becomes parallel to the z axis
- ❑ Scale such that the view volume becomes the canonical perspective view volume

$$N_{per} = S_{per} \bullet SH_{per} \bullet T(-PRP) \bullet R \bullet T(-VRP)$$

---

# Alternative Perspective Projection

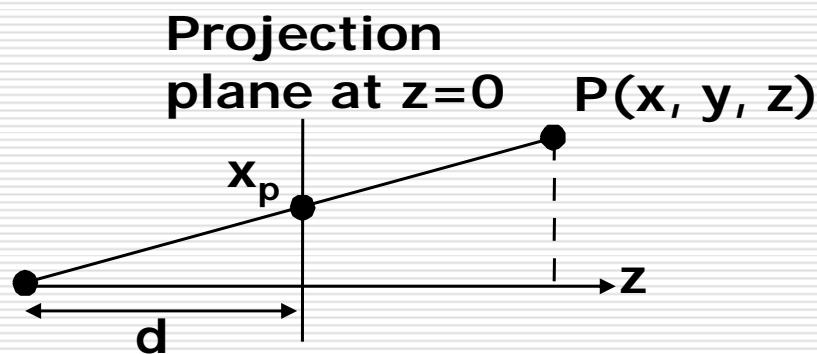

$$\frac{x_p}{d} = \frac{x}{z+d}; \frac{y_p}{d} = \frac{y}{z+d}$$

$$x_p = \frac{x}{(z/d)+1}; y_p = \frac{y}{(z/d)+1}$$

View along y axis

View along x axis

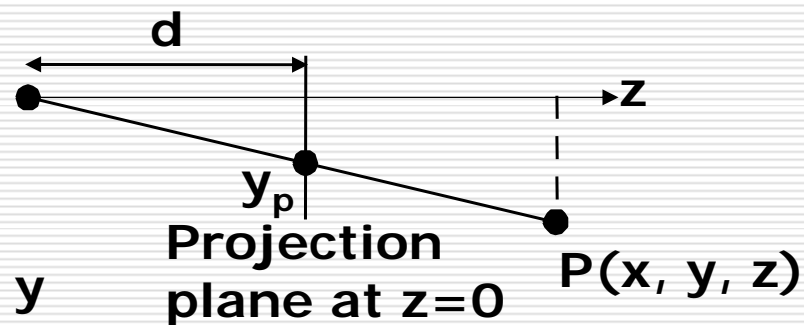

$$M'_{per} = \begin{bmatrix} 1 & 0 & 0 & 0 \\ 0 & 1 & 0 & 0 \\ 0 & 0 & 0 & 0 \\ 0 & 0 & 1/d & 1 \end{bmatrix}$$



# Vanishing Points

---

- Parallel lines (not parallel to the projection plan) on the object converge at a single point in the projection (the *vanishing point*)
- Drawing simple perspectives by hand uses these vanishing point(s)

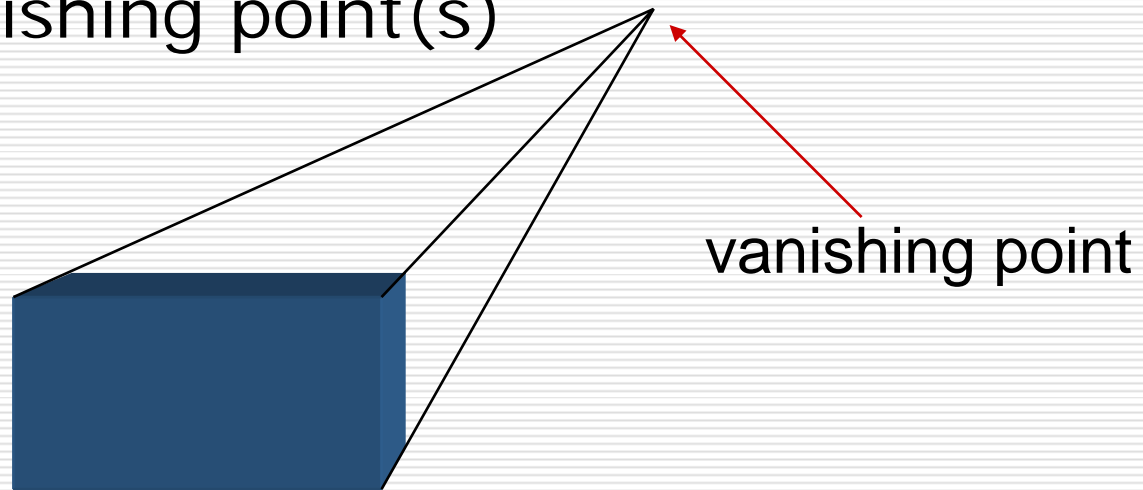

# Three-Point Perspective

---

- ❑ No principal face parallel to projection plane
- ❑ Three vanishing points for cube

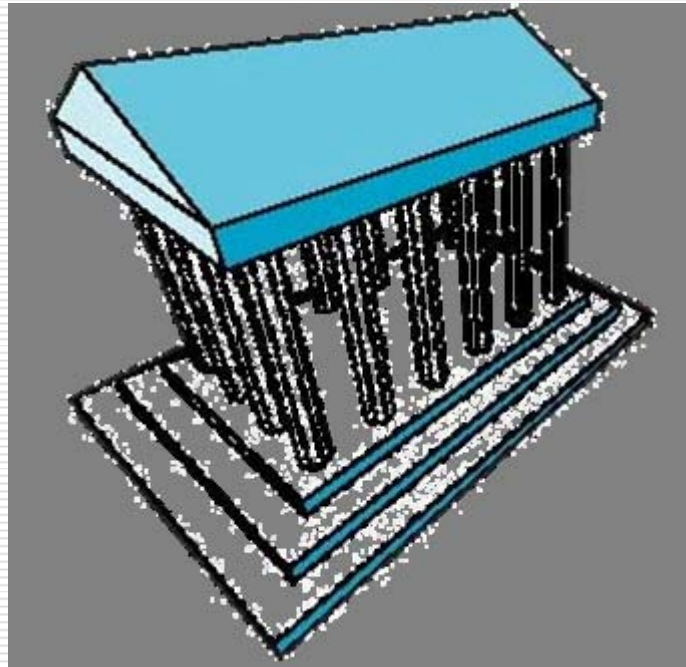

# Two-Point Perspective

---

- ❑ On principal direction parallel to projection plane
- ❑ Two vanishing points for cube



# One-Point Perspective

---

- ❑ One principal face parallel to projection plane
- ❑ One vanishing point for cube

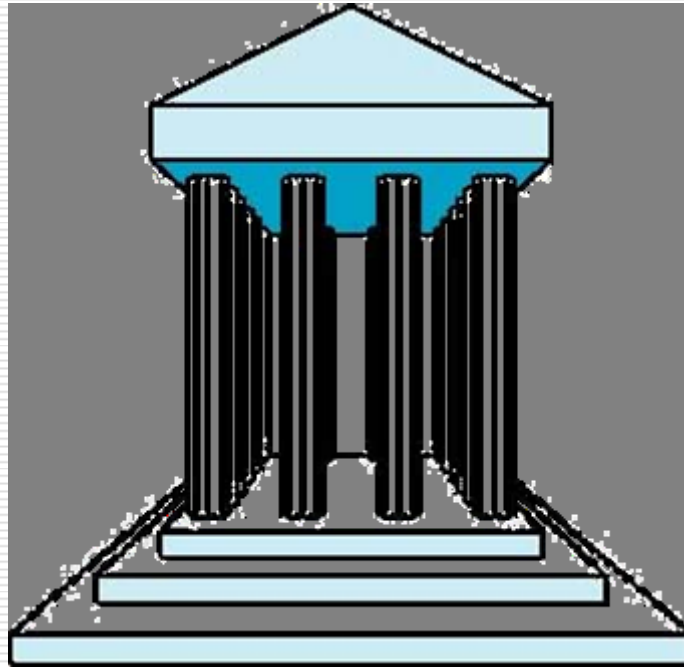

# Advantages and Disadvantages

---

- Objects further from viewer are projected smaller than the same sized objects closer to the viewer (*diminution*)
    - Looks realistic
  - Equal distances along a line are not projected into equal distances (*nonuniform foreshortening*)
  - Angles preserved only in planes parallel to the projection plane
  - More difficult to construct by hand than parallel projections (but not more difficult by computer)
-

# Canonical View Volume for Orthographic Parallel Projection

---

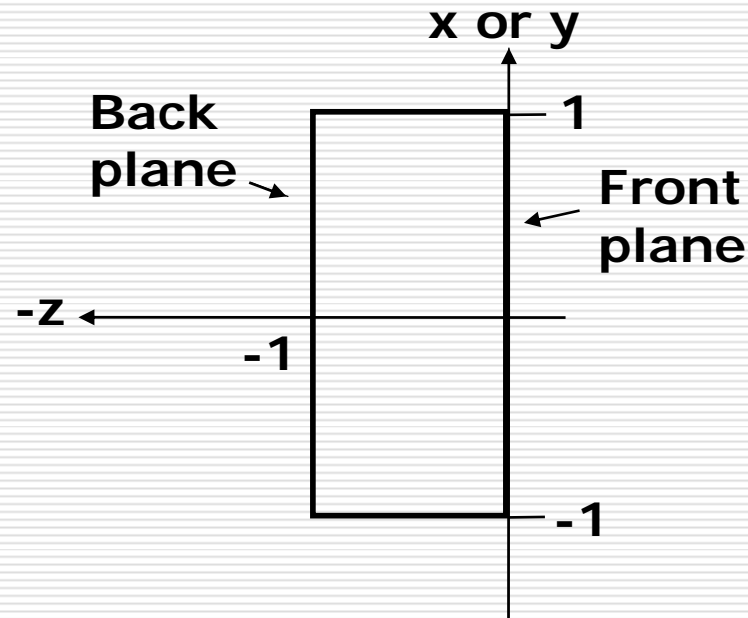

- $x = -1, y = -1, z = 0$
  - $x = 1, y = 1, z = -1$
-

# The Extension of the Cohen-Sutherland Algorithm

---

- ❑ bit 1 – point is above view volume  $y > 1$
  - ❑ bit 2 – point is below view volume  $y < -1$
  - ❑ bit 3 – point is right of view volume  $x > 1$
  - ❑ bit 4 – point is left of view volume  $x < -1$
  - ❑ bit 5 – point is behind view volume  $z < -1$
  - ❑ bit 6 – point is in front of view volume  $z > 0$
-

# Intersection of a 3D Line

---

□ a line from  $P_0(x_0, y_0, z_0)$  to  $P_1(x_1, y_1, z_1)$  can be represented as  $x = x_0 + t(x_1 - x_0)$

$$y = y_0 + t(y_1 - y_0)$$

$$z = z_0 + t(z_1 - z_0) \quad 0 \leq t \leq 1$$

□ so when  $y = 1$

$$x = x_0 + \frac{(1 - y_0)(x_1 - x_0)}{y_1 - y_0}$$

$$z = z_0 + \frac{(1 - y_0)(z_1 - z_0)}{y_1 - y_0}$$

---



# Canonical View Volume for Perspective Projection

---

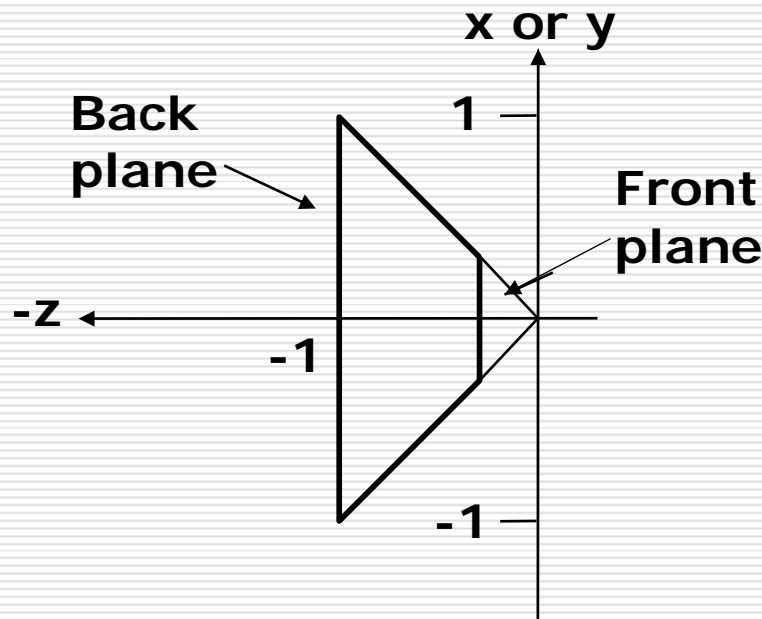

- $x = z, y = z, z = -z_{\min}$
  - $x = -z, y = -z, z = -1$
-

# The Extension of the Cohen-Sutherland Algorithm

---

- bit 1 – point is above view volume  $y > -z$
  - bit 2 – point is below view volume  $y < z$
  - bit 3 – point is right of view volume  $x > -z$
  - bit 4 – point is left of view volume  $x < z$
  - bit 5 – point is behind view volume  $z < -1$
  - bit 6 – point is in front of view volume  $z > z_{\min}$
-

# Intersection of a 3D Line

---

□ so when  $y = z$

$$x = x_0 + \frac{(x_1 - x_0)(z_0 - y_0)}{(y_1 - y_0) - (z_1 - z_0)}$$

$$y = y_0 + \frac{(y_1 - y_0)(z_0 - y_0)}{(y_1 - y_0) - (z_1 - z_0)}$$

$$z = y$$

---

# Clipping in Homogeneous Coordinates

---

- Why clip in **homogeneous coordinates** ?
  - it is possible to transform the *perspective-projection canonical view volume* into the *parallel-projection canonical view volume*

$$M = \begin{bmatrix} 1 & 0 & 0 & 0 \\ 0 & 1 & 0 & 0 \\ 0 & 0 & \frac{1}{1+z_{\min}} & \frac{-z_{\min}}{1+z_{\min}} \\ 0 & 0 & -1 & 0 \end{bmatrix}, z_{\min} \neq -1$$

---

# Clipping in Homogeneous Coordinates

---

- The corresponding plane equations are
    - $X = -W$
    - $X = W$
    - $Y = -W$
    - $Y = W$
    - $Z = -W$
    - $Z = 0$
-